

Webinar #2: Tackling Physics Problems

24th June 2026

Written and presented by Dr Justin Palfreyman

1. Bouncy Ball

A ball of mass 0.125 kg bounces on a hard surface. Every time it hits the floor, it loses a quarter of its kinetic energy. The ball is released from a height of 1.00 m.

After how many bounces will the ball bounce no higher than 0.25 m?

2. The Snowman

You want to make a snowman out of modelling clay. The snowman consists of two spheres, where one sphere has a radius r , and the other has a radius $2r$. The modelling clay comes in the form of a cylinder with radius $r/2$.



What length of modelling clay is required to make the snowman?

3. Mass on springs

A mass m is hung from a spring with a spring constant of k . When set into motion, the mass oscillates with a period $T = 2\pi\sqrt{\frac{m}{k}}$.

Using another identical spring, What would be the period of oscillation of the mass if it were...

- taken to a planet with a gravitational field strength of $2g$.
- hung from the two springs connected end-to-end (in series)?
- hung from the two springs connected side-by-side (in parallel)?

4. **Infinite resistors - Part I**

If, in the diagram below¹, $R_1 = 10\Omega$, $R_2 = 20\Omega$ and $V = 10V$, find the current, I .

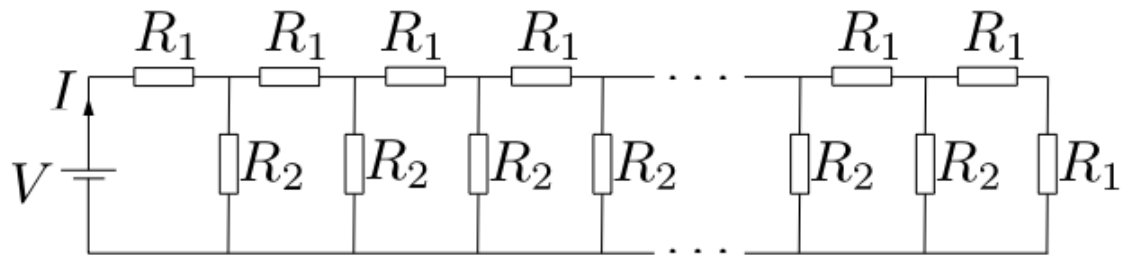

5. **Tangled resistor circuit** [No calculator]

If this tangled network of 13 resistors were to be replaced with a single resistor that would draw the same current from the battery, what value resistor should be chosen?

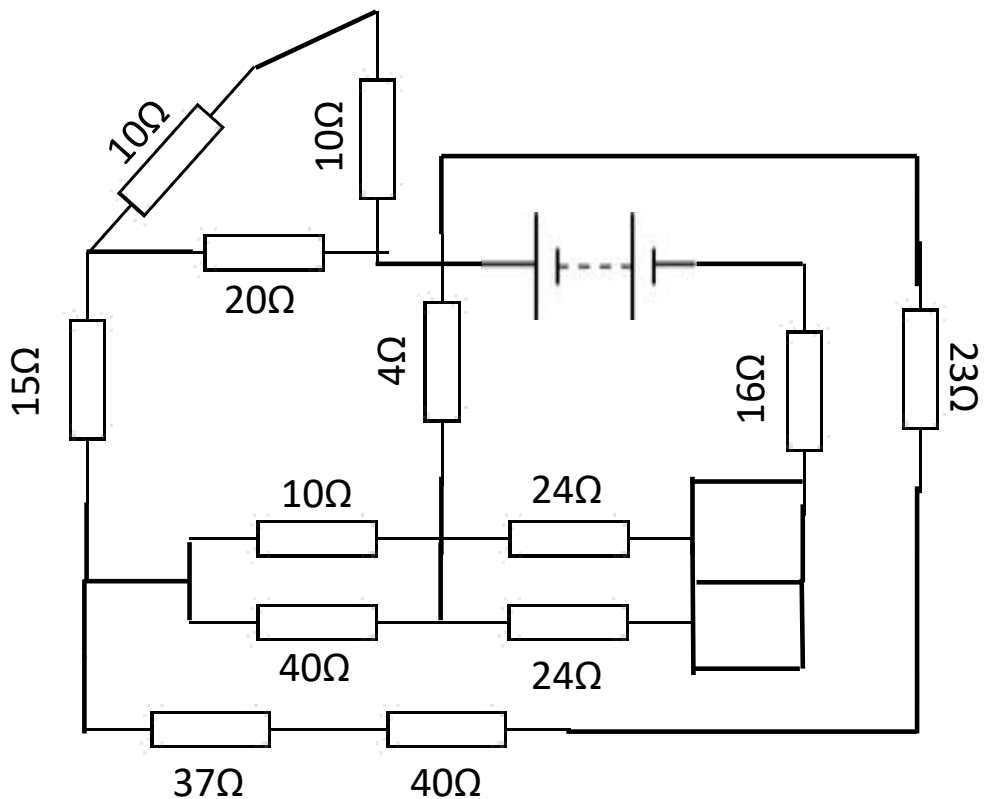

¹ https://i-want-to-study-engineering.org/q/infinite_loops_circuit_1

6. Resistor networks - Part I

A cube of resistors, ABCDEFGH, is made with 12 identical resistors of resistance $R = 12\Omega$.
An ohmmeter is connected to vertices A and D.

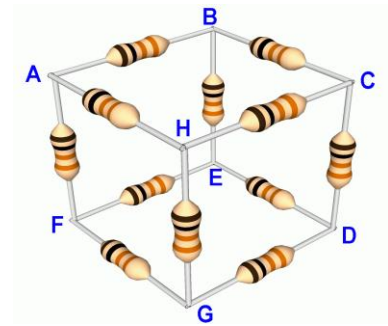

Determine the reading on the ohmmeter.

7. Motion-time graphs - Part I

A ball is thrown up in the air, losing contact with the hand at time $t = 0$ and then caught at the same height at time $t = t_1$. Draw the velocity-time sketch for the motion of the ball for $0 \leq t \leq t_1$.

Hint: Ignore air resistance

8. Maximum range - Part I

Show that the maximum range of a cannon on flat ground is achieved by launching at an angle above the horizontal of $\theta = 45^\circ$.

9. Plutonian Caterpillars

The dwarf planet Pluto (radius 1180 km) is populated by three species of purple caterpillar. Studies have established the following facts:

- A line of 5 mauve caterpillars is as long as a line of 7 violet caterpillars.
- A line of 3 lavender caterpillars and 1 mauve caterpillar is as long as a line of 8 violet caterpillars.
- A line of 5 lavender caterpillars, 5 mauve caterpillars and 2 violet caterpillars is 1 m long in total.
- A lavender caterpillar takes 10 s to crawl the length of a violet caterpillar.
- Violet and mauve caterpillars both crawl twice as fast as lavender caterpillars.

How long would it take a mauve caterpillar to crawl around the equator of Pluto?

Building The Great Pyramid of Giza – Part I

There are several theories (including aliens) to explain how the ancient Egyptians were able to build these megastructures with such primitive technology. The mainstream theory believes that skilled workers (not slaves) dragged the blocks up ramps. Let's explore whether this is physically feasible...

10. Rate of Construction

The great pyramid at Giza was mostly made from an estimated 2.3 million blocks of limestone, each one with a mass of approximately 2.5 tonne. Egyptologists have estimated the construction² only took 18 years.

Estimate the rate, in blocks per hour, at which the pyramid was constructed. State any assumptions you make.

11. Dimensions

When the pyramid was originally built it had a square base of side length 230 m and a corner-apex distance of 221 m as shown.

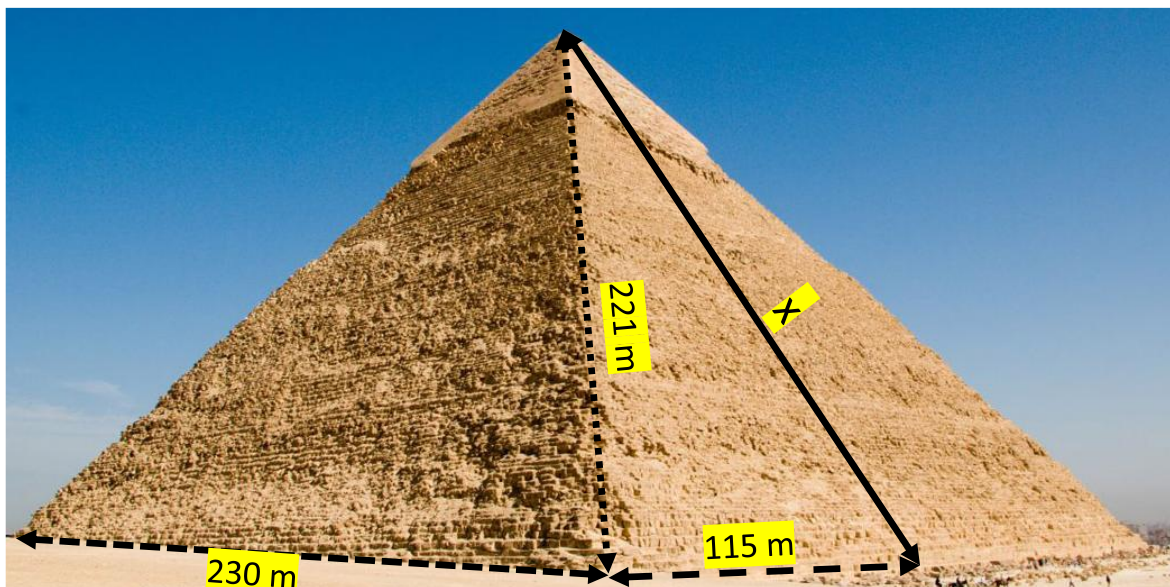

Calculate the vertical height of the pyramid and the length of the slope mid-way along a side, marked x in the photograph.

12. Pulling Force

² Although with the planning, it was probably a 27 year project: [chrome-extension://efaidnbmnnnibpcajpcglclefindmkaj/https://fundacionieae.es/wp-content/uploads/2024/08/Brichieri-Colombi_PJAE_12_1_2015.pdf](https://fundacionieae.es/wp-content/uploads/2024/08/Brichieri-Colombi_PJAE_12_1_2015.pdf)

The coefficient of static friction between sand & wood is around 0.7. Assume the team of twenty workers is each able to apply a force equal to their body weight.

Show that the incline of the side of the pyramid is close to the hardest angle for dragging the limestone blocks up it and calculate the mass of the workers that would be required. Compare this to the estimated mass of 46 kg.

13. Simple Ramp

A discovery made in 2018 suggests the ancient Egyptians were using primitive pulleys to increase the force they could apply.

Step-by-step guide

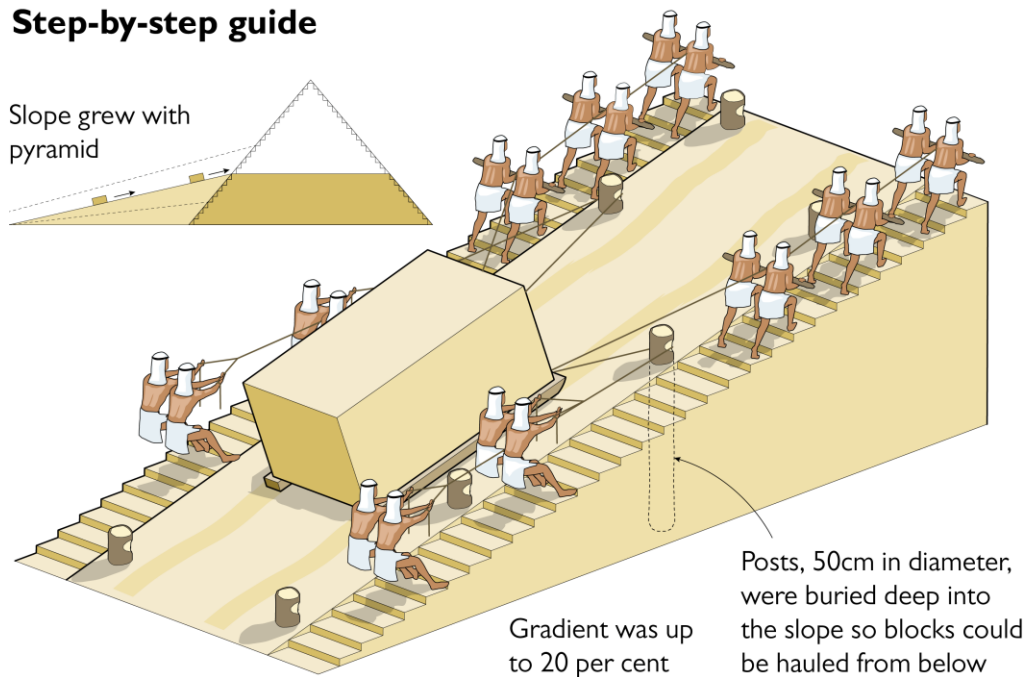

Using the information in the picture above, estimate the volume of the final ramp structure and compare this to the volume of the great pyramid.