

Study Focus 2: Setting up physics problems

This study focus session contains problems covering a wide variety of topics, but they all may involve pausing to plan your route through a question before putting pen to paper. Setting up a problem well before working through the maths is an essential skill for any physicist, and we hope these questions are challenging but rewarding!

Introductory Problems

You will not need a calculator for any of these problems.

1. Rectangle ABCD has an area of 120 cm^2 . Find the area of the shaded part.

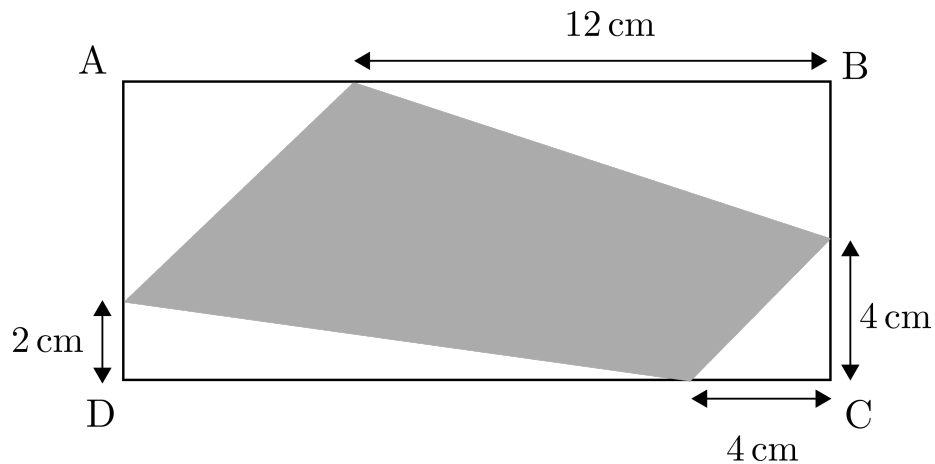

Figure 1: Shaded rectangle ABCD

2. A ball is at rest at the top of a frictionless hill. It is then given a slight nudge and speeds up to 4 ms^{-1} at the bottom of the hill. If the ball had a speed of 3 ms^{-1} at the top of the hill (instead of being stationary), what would its speed now be at the bottom?
3. A $10 \times 10 \times 10$ cube is constructed from a thousand unit cubes. How many of the unit cubes have at least one face on the surface of the larger cube?
4. A bartender pours 100 ml of tonic water into one glass and 100 ml of gin into another. He then takes a 30 ml shot glass and scoops a shot of gin into the tonic and gives it a good mix. He then takes the shot glass and transfers 30 ml of the mix back into the gin glass. Is there more tonic in the gin glass, or more gin in the tonic glass?
5. A race has 2022 entrants, all numbered from 1 to 2022 at random. What is the probability that the first three runners to cross the finish line are numbered in ascending order?
6. An ant is at one corner of a cube of side length a . What is the minimum distance it must travel to reach the far corner of the cube, assuming it can only walk on the faces and can't tunnel through?

Further Problems

7. Each summer, when the grass grows to a certain height, the groundsman goes to the uniform cow shop and rents some uniform cows to graze on it, until it reaches a particular level. From the previous 2 years the groundsman knows that it took:
 - Year 1: 6 cows, 4 days to do the job
 - Year 2: 3 cows, 9 days to do the job
 This year only 1 uniform cow is available. How many days will it take for the cow to do the job?
8. A piranha-infested river runs from west to east, as depicted in Figure 2. Sarah Connor is living off the grid 3 km north of the river and does not have access to fresh water. Following a recent impaling, she is unable to walk. Her survival is vital for the future of humanity. Each day Kyle Rees, who lives 2 km north of the river and 12 km west of Sarah Connor, must travel from his hideout with a bucket, which he fills with water from the river. He must save as much energy as possible for the fight against the machines. What is the minimum distance he needs to travel to get to Sarah's house via the river?

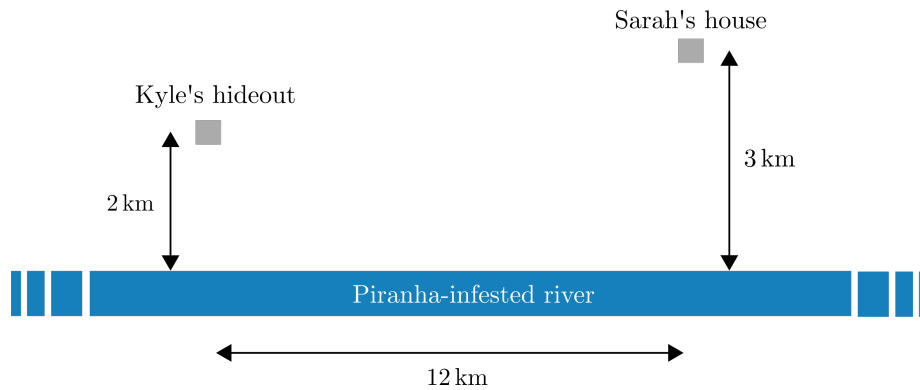

Figure 2: Sarah Connor's house and Kyle Rees' hideout

9. A person travels from Newcastle to Oxford by coach. Traffic is free-flowing and the coach's speed is only limited by whether the road is flat (63 mph), uphill (56 mph) or downhill (72 mph). The coach ride takes 4 hours from Newcastle to Oxford, but the return journey, which follows the same roads, takes an hour longer. How many miles is the coach ride between Newcastle and Oxford?

10. It's finally time for a battle to end the long-running dispute between pirates and ninjas. They face off at 90 m. The pirate limps towards the ninja at 2 m s^{-1} , while the ninja glides towards the pirate at twice the speed. It is only a matter of time before they collide and crush the loyal parrot which repeatedly flies back and forth at a constant speed of 8 m s^{-1} , elastically bouncing off the two. What is the total distance the parrot travels before being crushed?

Extension Problems

11. Tangled resistor circuit

No calculator

If the two circuits in Figure 3 shown are equivalent, what is the value of R_{TOTAL} ?

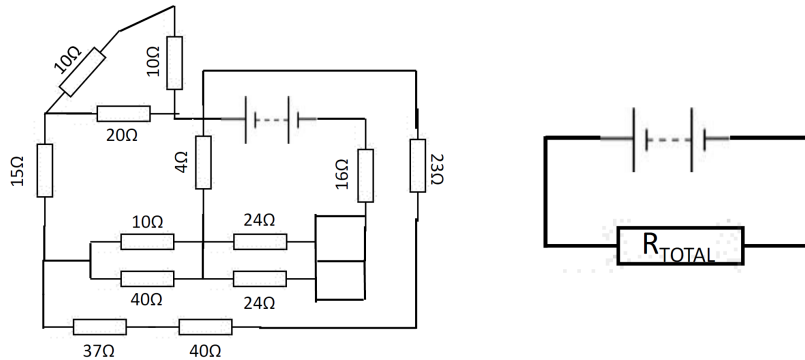

Figure 3: Two resistor networks

12. Marble in a Fishbowl

No calculator

A 'fishbowl' of height $\frac{4r}{3}$ is formed by removing the top third of a sphere (of radius r). The fishbowl is fixed in sand so that its rim is parallel with the ground. A small marble of mass m rests at the bottom of the fishbowl. Assuming all surfaces are frictionless and ignoring air resistance, find the maximum initial velocity that could be given to the marble for it to land back in the fishbowl.

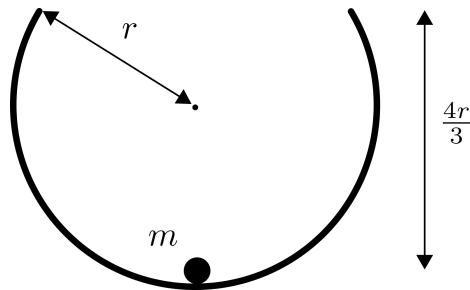

Figure 4: A marble at rest at the bottom of a fishbowl.

13. **Trusses**

No calculator, use $g \approx 10 \text{ ms}^{-2}$

A ball of weight 500 N is suspended from the apex of the structure shown in Figure 5. The structure is made of two trusses, each of length 3.0 m and mass 40 kg. A 3.0 m horizontal rope connects the trusses, tied a sixth of the way up the trusses. If the structure were placed on an ice-rink, calculate the resulting tension in the rope.



Figure 5: Trusses with a suspended ball

14. **Maximum range**

- (a) Show that the maximum range of a cannon on flat ground is achieved by launching at an angle above the horizontal of $\theta = 45^\circ$.
- (b) Show that, if the cannon is at the top of a hill, with an incline of ϕ , then the range equation can now be written as

$$R = \frac{u^2}{g} [\sin 2\theta + \tan \phi (1 + \cos 2\theta)]. \quad (1)$$

- (c) Determine the relationship between θ and ϕ that maximizes the range.

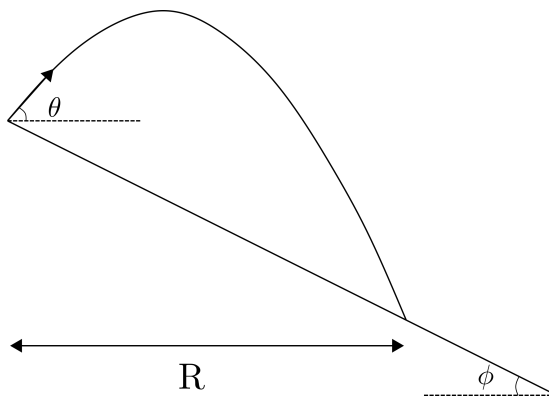

Figure 6: The trajectory of a cannonball being fired at an angle θ to the horizontal at the top of a hill with an incline of ϕ .

15. **Monkey-shoot**

A zookeeper needs to tranquilise a monkey, who is too shy to come down from the trees, by hitting it with a dart from a tranquiliser gun and catching it in a net as it falls.

- (a) If the monkey does not move, should the zookeeper aim above, at, or below the monkey?
- (b) If the monkey lets go of the branch at the instant the zookeeper shoots the dart, should the zookeeper aim above, at or below the monkey to hit the monkey in mid-air?

Once you have decided on your answers to this problem, use SUVAT to confirm them.

16. **Motion-time graphs**

For the following scenarios, sketch the motion-time graphs (displacement-time, velocity-time and acceleration-time).

- (a) A ball is thrown up in the air and then caught at the same height. Only sketch from the instant the ball leaves the hand to the instant it touches the hand again. Ignore air resistance.
- (b) A train travels from Birmingham to Oxford, stopping only at Banbury on route. You may assume the journey is in a straight line and it only takes a few minutes of constant acceleration/deceleration to get to its top speed/come to a stop.
- (c) A football is dropped from a great height (such that it reaches terminal velocity); it bounces inelastically such that air resistance can be ignored from this point. Sketch the motion from the moment of release until it hits the ground for a second time.

17. **Resistor networks**

A cube of resistors, ABCDEFGH, is made with 12 identical resistors of resistance R , shown in Figure 7. A multimeter probe is used to measure its resistance. One wire is connected to vertex A, and the other probe is moved around the other vertices in turn. Determine the resistance reading in each position.

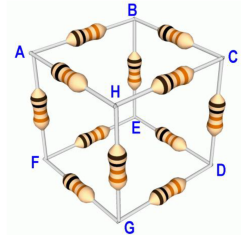

Figure 7: A network of 12 identical resistors of resistance R

Hints to Chapter 2

Introductory Problems

1. Try breaking the shaded area up into more familiar shapes. For every unshaded triangle, can you find an equivalent shaded triangle?
2. Why do you think the mass of the ball has not been specified? Have you identified which conservation law is useful here? Do not substitute numbers too early. Do you need to evaluate the height?
3. How will you deal with the edges and corners? Could you ask a different question that is almost equivalent to give the answer in one step?
4. What is the final volume of liquid in each glass? Although numbers are given here, they are not necessary to solve this.
5. Would it make a difference if there were only 2020 runners? It may be useful not to focus on the numbers: why not label the winners A, B and C?
6. Can you turn this into a 2-dimensional problem?

Further Problems

7. The reason that it doesn't take the 3 cows 8 days to do the job: the grass is growing! Make sure you take this into account. Consider units: what does a cow-day represent physically? What does a cow-day per day represent physically?
8. What is the quickest way between any two points? Can you ask an equivalent question following the path of a ray of light? One approach would be to find the minimum distance using calculus, but there is a much neater solution.
9. Split the journey into 3 sections of length x , y and z . What happens to the downhill sections on the return journey? What are you trying to find in terms of x , y and z ? Do you care what each of them are? The numbers have been chosen carefully – can you tidy up awkward fractions?
10. One approach would be to find the positions where the parrot changes direction. Since we are given the speed, but asked to find distance, what else would it be useful to know?

Extension Problems

11. Tangled resistor circuit

Redraw the circuit in a more useful/recognizable format, and simplify pairs of resistors as you go. DO NOT try to do it all in one go.

12. Marble in a Fishbowl

Draw a large, clear diagram with all key information labelled. Plan your route through the problem before putting pen to paper. If the initial velocity of the marble is v_0 and the velocity it flies out of the fishbowl is v_1 , why is $v_1 < v_0$ if all surfaces are frictionless? Can you solve for the motion of the marble in the air like you would a regular projectile problem? What physical principle will you need to use to relate v_1 to v_0 ?

13. Trusses

Think about how you might be able to simplify the problem. For example: where might be the best place to take moments about? Make sure you have a clear diagram with all forces labelled.

14. Maximum range

(a) You'll find it helpful for this particular problem to know that

$$2 \sin x \cos x \equiv \sin 2x \quad (2)$$

In general, follow this step-by-step guide and you'll solve most projectile problems.

- i. Draw a clear diagram showing all the information given and what you're asked to find.
 - ii. Split any velocity vectors (usually given the initial velocity) into horizontal and vertical components.
 - iii. Set up sign convention: which horizontal (x) and vertical (y) directions are positive?
 - iv. Write out 2 sets of SUVAT, being careful about minus signs.
 - v. The time of flight will be the same in both directions, so you can often find this by resolving vertically and use this to find the horizontal range.
- (b) A clear diagram is always important, more so for tricky problems like this. A stepping stone along the way will be this equation:

$$\frac{1}{2}gt^2 - u \sin \theta t - R \tan \phi = 0. \quad (3)$$

You'll find it helpful here to know that

$$\cos 2x \equiv 1 - 2 \sin^2 x \quad (4)$$

- (c) Sorry – there’s no clever shortcut here, you’re going to have to differentiate! You’ll find it helpful here to know that

$$\cot \phi = \tan \left(\frac{\pi}{2} - \phi \right) \quad (5)$$

Your final expression should be reassuringly simple, and it must resemble what you should have found in part (a) when $\phi = 0$.

15. Monkey-shoot

Figure out the time it takes for the arrow to cross the path of the monkey as a function of the angle which the zookeeper fires the dart. Is the height of the arrow and the monkey the same at this time?

16. Motion-time graphs

Your intuition will likely mislead you. Start with a free-body force diagram, link this to acceleration, and then link that to velocity and finally displacement. Split the journey up into regions when the behaviour changes.

17. Resistor networks

What are the symmetries? Re-draw the network in a more familiar format. No net current will flow between points with the same potential.